

EDS-505A/508A/516A Series

5, 8, and 16-port managed Ethernet switches



- > Turbo Ring, Turbo Chain, RSTP/STP, and MSTP* for network redundancy
- > TACACS+*, SNMPv3, IEEE 802.1X, HTTPS, and SSH to enhance network security
- > Easy network management by web browser, CLI*, Telnet/serial console, Windows utility, and ABC-01

*Available in Q3, 2011



Introduction

The EDS-505A/508A/516A are standalone 5, 8, and 16-port managed Ethernet switches. With their advanced Turbo Ring and Turbo Chain technology (recovery time < 20 ms), RSTP/STP, and MSTP* support the EDS-505A/508A/516A switches increase the reliability and availability of your industrial Ethernet network. Models with a wide

operating temperature range of -40 to 75°C are also available, and the switches support advanced management and security features, making the EDS-505A/508A/516A switches suitable for any harsh industrial environment.

*Available in Q3, 2011

Features and Benefits

- Command Line Interface (CLI) for quickly configuring major managed functions*
- IPv6 Ready logo awarded (IPv6 Logo Committee certified)
- IEEE 1588 PTP V2* (Precision Time Protocol) for precise time synchronization of networks
- DHCP Option 82 for IP address assignment with different policies
- Support EtherNet/IP* and Modbus/TCP protocols for device management and monitoring
- Compatible with EtherNet/IP and PROFINET protocols for transparent data transmission
- Turbo Ring and Turbo Chain (recovery time < 20 ms), RSTP/STP, and MSTP* for network redundancy
- IGMP snooping and GMRP for filtering multicast traffic
- Port-based VLAN, IEEE 802.1Q VLAN, and GVRP to ease network planning
- QoS (IEEE 802.1p/1Q) and TOS/DiffServ to increase determinism
- Port Trunking for optimum bandwidth utilization
- RMON for efficient network monitoring and proactive capability
- SNMPv1/v2c/v3 for different levels of network management
- TACACS+*, SNMPv3, IEEE 802.1X, HTTPS, and SSH to enhance network security
- Bandwidth management to prevent unpredictable network status
- Lock port function for blocking unauthorized access based on MAC address
- Automatic warning by exception through e-mail, relay output

*Available in Q3, 2011

Specifications

Technology

Standards:

- IEEE 802.3 for 10BaseT
- IEEE 802.3u for 100BaseT(X) and 100BaseFX
- IEEE 802.3x for Flow Control
- IEEE 802.1D-2004 for Spanning Tree Protocol*
- IEEE 802.1w for Rapid STP
- IEEE 802.1s for Multiple Spanning Tree Protocol*
- IEEE 802.1Q for VLAN Tagging
- IEEE 802.1p for Class of Service
- IEEE 802.1X for Authentication
- IEEE 802.3ad for Port Trunk with LACP

Protocols: IGMPv1/v2, GVRP, SNMPv1/v2c/v3, DHCP Server/Client, BootP, TFTP, SNMP, SMTP, RARP, GMRP, LACP, RMON, HTTP, HTTPS, Telnet, Syslog, DHCP Option 66/67/82, SSH, SNMP Inform, EtherNet/IP*, Modbus/TCP, LLDP, IEEE 1588 PTP V2*, IPv6, NTP Server/Client*

MIB: MIB-II, Ethernet-Like MIB, P-BRIDGE MIB, Q-BRIDGE MIB, Bridge MIB, RSTP MIB, RMON MIB Group 1, 2, 3, 9

Flow Control: IEEE 802.3x flow control, back pressure flow control

*Available in Q3, 2011

Switch Properties

- Priority Queues:** 4
- Max. Number of Available VLANs:** 64
- VLAN ID Range:** VID 1 to 4094
- IGMP Groups:** 256
- MAC Table Size:** 8 K
- Packet Buffer Size:** 1 Mbit (EDS-505A/508A), 2 Mbit (EDS-516A)

Interface

- Fiber Ports:** 100BaseFX ports (SC/ST connector)
- RJ45 Ports:** 10/100BaseT(X) auto negotiation speed, Full/Half duplex mode, and auto MDI/MDI-X connection
- Console Port:** RS-232 (RJ45 connector)
- DIP Switches:** Turbo Ring, Master, Coupler, Reserve (EDS-505A/508A series only)

LED Indicators: PWR1, PWR2, FAULT, MSTR/HEAD, CPLR/TAIL, 10/100M

Alarm Contact: 2 relay outputs with current carrying capacity of 1 A @ 24 VDC

Digital Inputs: 2 inputs with the same ground, but electrically isolated from the electronics.

- +13 to +30V for state “1”
- -30 to +3V for state “0”
- Max. input current: 8 mA

Optical Fiber

	100BaseFX		
	Multi-mode	Single-mode	Single-mode, 80 km
Wavelength	1300 nm	1310 nm	1550 nm
Max. TX	-10 dBm	0 dBm	0 dBm
Min. TX	-20 dBm	-5 dBm	-5 dBm
RX Sensitivity	-32 dBm	-34 dBm	-34 dBm
Link Budget	12 dB	29 dB	29 dB
Typical Distance	5 km ^a 4 km ^b	40 km ^c	80 km ^d
Saturation	-6 dBm	-3 dBm	-3 dBm

- a. 50/125 μm, 800 MHz*km fiber optic cable
- b. 62.5/125 μm, 500 MHz*km fiber optic cable
- c. 9/125 μm single-mode fiber optic cable
- d. 9/125 μm single-mode fiber optic cable (80 km)

Power Requirements

Input Voltage: 24 VDC (12 to 45 VDC), redundant dual inputs

Input Current:

- EDS-505A: 0.24 A @ 24 V
- EDS-505A-MM/SS: 0.35 A @ 24 V
- EDS-508A: 0.26A @ 24 V
- EDS-508A-MM/SS: 0.36 A @ 24 V
- EDS-516A: 0.41 A @ 24 V
- EDS-516A-MM: 0.51 A @ 24 V

Overload Current Protection: Present

Connection: 2 removable 6-contact terminal blocks

Reverse Polarity Protection: Present

Physical Characteristics

Housing: Metal, IP30 protection

Dimensions:

EDS-505A/508A Series: 80.2 x 135 x 105 mm

(3.16 x 5.31 x 4.13 in)

EDS-516A Series: 94 x 135 x 142.7 mm (3.7 x 5.31 x 5.62 in)

Weight:

EDS-505A/508A Series: 1040 g

EDS-516A Series: 1586 g

Installation: DIN-Rail mounting, wall mounting (with optional kit)

Environmental Limits

Operating Temperature:

Standard Models: 0 to 60°C (32 to 140°F)

Wide Temp. Models: -40 to 75°C (-40 to 167°F)

Storage Temperature: -40 to 85°C (-40 to 185°F)

Ambient Relative Humidity: 5 to 95% (non-condensing)

Standards and Certifications

Safety: UL 508, UL 60950-1, CSA C22.2 No. 60950-1, EN 60950-1

Hazardous Location: UL/cUL Class I Division 2 Groups A/B/C/D, ATEX Zone 2 Ex nC IIC

EMI: FCC Part 15 Subpart B Class A, EN 55022 Class A

EMS:

EN 61000-4-2 (ESD) (EDS-505A/508A: Level 3; EDS-516A: Level 2),

EN 61000-4-3 (RS) Level 3, EN 61000-4-4 (EFT) Level 2,

EN 61000-4-5 (Surge) Level 3, EN 61000-4-6 (CS) Level 3,

EN 61000-4-8

Marine: DNV, GL

Shock: IEC 60068-2-27

Freefall: IEC 60068-2-32

Vibration: IEC 60068-2-6

Note: Please check Moxa's website for the most up-to-date certification status.

MTBF (mean time between failures)

Time:

EDS-505A Series: 352,000 hrs

EDS-508A Series: 339,000 hrs

EDS-516A Series: 247,000 hrs

Database: Telcordia (Bellcore), GB

Warranty

Warranty Period: 5 years

Details: See www.moxa.com/warranty

Dimensions

EDS-505A/508A Series

Unit: mm (inch)

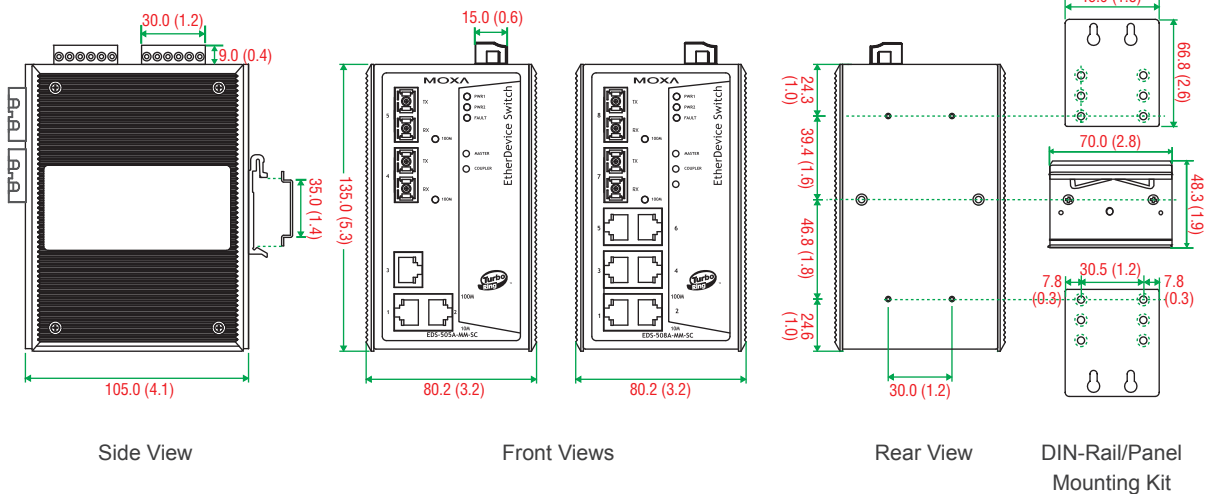

Dimensions

EDS-516A Series

Unit: mm (inch)

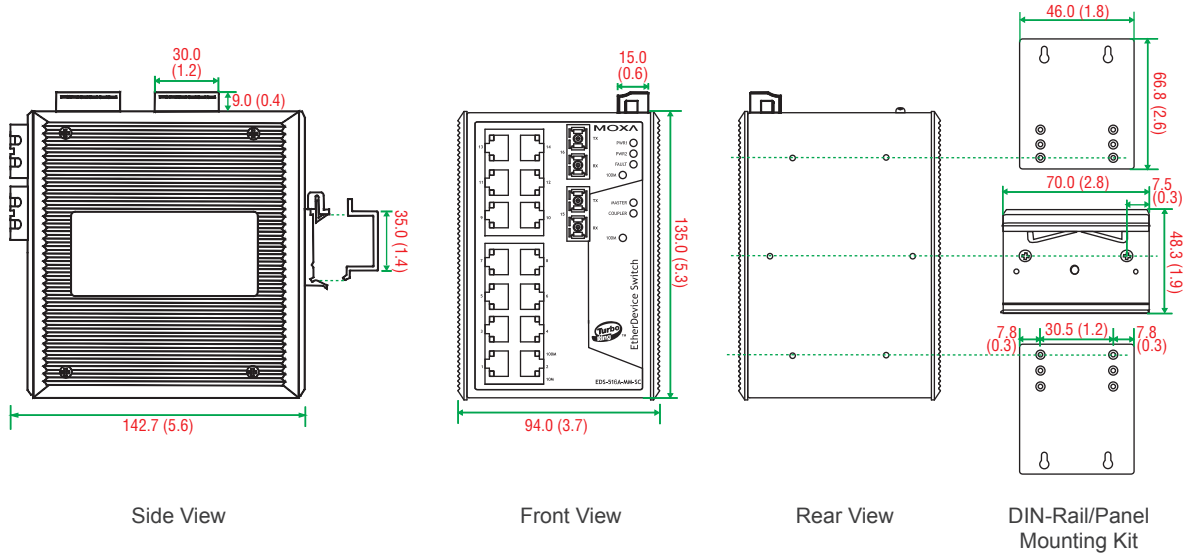

Ordering Information

Available Models		Port Interface				
Standard Temperature (0 to 60°C)	Wide Temperature (-40 to 75°C)	10/100BaseT(X)	100BaseFX			
			Multi-mode, SC Connector	Multi-mode, ST Connector	Single-mode, SC Connector	Single-mode, SC Connector, 80 km
EDS-505A/508A Series						
EDS-505A/508A	EDS-505A/508A-T	5/8	-	-	-	-
EDS-505A/508A-MM-SC	EDS-505A/508A-MM-SC-T	3/6	2	-	-	-
EDS-505A/508A-MM-ST	EDS-505A/508A-MM-ST-T	3/6	-	2	-	-
EDS-505A/508A-SS-SC	EDS-505A/508A-SS-SC-T	3/6	-	-	2	-
EDS-505A/508A-SS-SC-80	-	3/6	-	-	-	2
EDS-516A Series						
EDS-516A	EDS-516A	16	-	-	-	-
EDS-516A-MM-SC	EDS-516A-MM-SC-T	14	2	-	-	-
EDS-516A-MM-ST	EDS-516A-MM-ST-T	14	-	2	-	-

Optional Accessories (can be purchased separately)

MXview: Moxa industrial network management software with 50, 100, 250, 500, or 1000 nodes

EDS-SNMP OPC Server Pro: OPC server software that works with all SNMP devices

ABC-01: Configuration backup and restoration tool for managed Ethernet switches, 0 to 60°C operating temperature

DR-4524/75-24/120-24: 45/75/120 W DIN-Rail 24 VDC power supplies

MDR-40-24/60-24: 40/60 W DIN-Rail 24 VDC power supplies, -20 to 70°C operating temperature

WK-46: Wall mounting kit

RK-4U: 4U-high 19" rack mounting kit

Package Checklist

- EDS-505A or EDS-508A or EDS-516A switch
- RJ45 to DB9 console port cable
- Protective caps for unused ports
- Documentation and software CD
- Hardware installation guide (printed)
- Warranty card